



SELF-CONTAINED CUBER

**IM-21CPE
IM-30CPE
IM-30CPE-25
IM-30CWPE
IM-30CWPE-25**

PARTS LIST

[HE]

M109
M110
M110-D001,D002,D003
M110-D200,D201,D202,D203
M110-D300,D301,D302,D303

P-0 DEC. 2024

List of Specifications

IM-21CPE	M109	Air-cooled Standard
IM-30CPE	M110	Air-cooled Standard
IM-30CPE-25	M110-D001	25mm ICE of IM-30CPE
IM-30CWPE	M110-D002	Water-cooled Standard
IM-30CWPE-25	M110-D003	25mm ICE of IM-30CWPE
IM-30CPE-U	M110-D200	Air-cooled Standard
IM-30CPE-U-25	M110-D201	25mm ICE of IM-30CPE
IM-30CWPE-U	M110-D202	Water-cooled Standard
IM-30CWPE-U-25	M110-D203	25mm ICE of IM-30CWPE
IM-30CPE-E	M110-D300	Air-cooled Standard
IM-30CPE-E-25	M110-D301	25mm ICE of IM-30CPE
IM-30CWPE-E	M110-D302	Water-cooled Standard
IM-30CWPE-E-25	M110-D303	25mm ICE of IM-30CWPE

List of Functions

Basic		Cube
Basic + DP	F	FlexCube
Basic + UV	U	UltraCube
Basic + IoT + DP + UV	E	EliteCube

Auxiliary Codes

Auxiliary Code Breakdown

The auxiliary code is the first two characters in the serial number. The first character indicates the year. Years progress or regress in alphabetical order. The series runs from "A" through "V" and the letters "I" and "O" are skipped. The second character indicates significant part changes within a year. Base is "0" and this number advances for each change. In cases where there is a letter in parentheses, this designates the month. This is the last character in the serial number. The series runs from "(A)" through "(M)" and the letter "(I)" is skipped. This designation is only included when identifying a parts change within an auxiliary code.

Note About Ordering Parts

Most assemblies cannot be ordered as complete units; parts in the assemblies generally must be ordered separately.

MARKS LOCATED UNDER THE AUXILIARY CODE

- = Part deleted.

FASTENER PART NUMBER

SCREWS

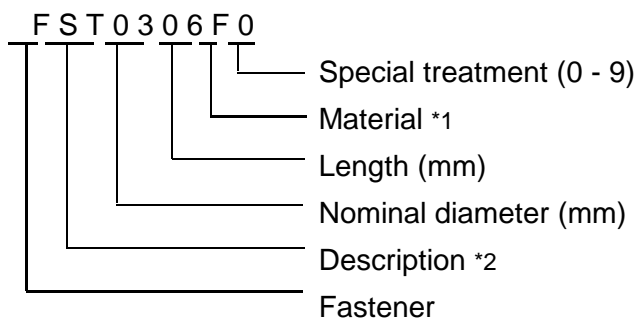

*1 Material

- F: Steel
- S: Austenitic stainless steel
- M: Martensitic stainless steel
- B: Copper alloy
- P: Polycarbonate
- N: Polyamide
- V: PVC
- A: ABS
- X: Polyacetal
- L: Aluminum

NUTS & WASHERS

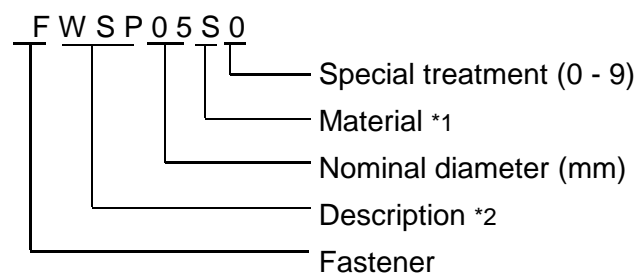

*2 Description

- First letter
- S: Machine screw
- T: Tapping screw
- M: Wood screw
- B: Bolt
- W: Washer
- N: Nut

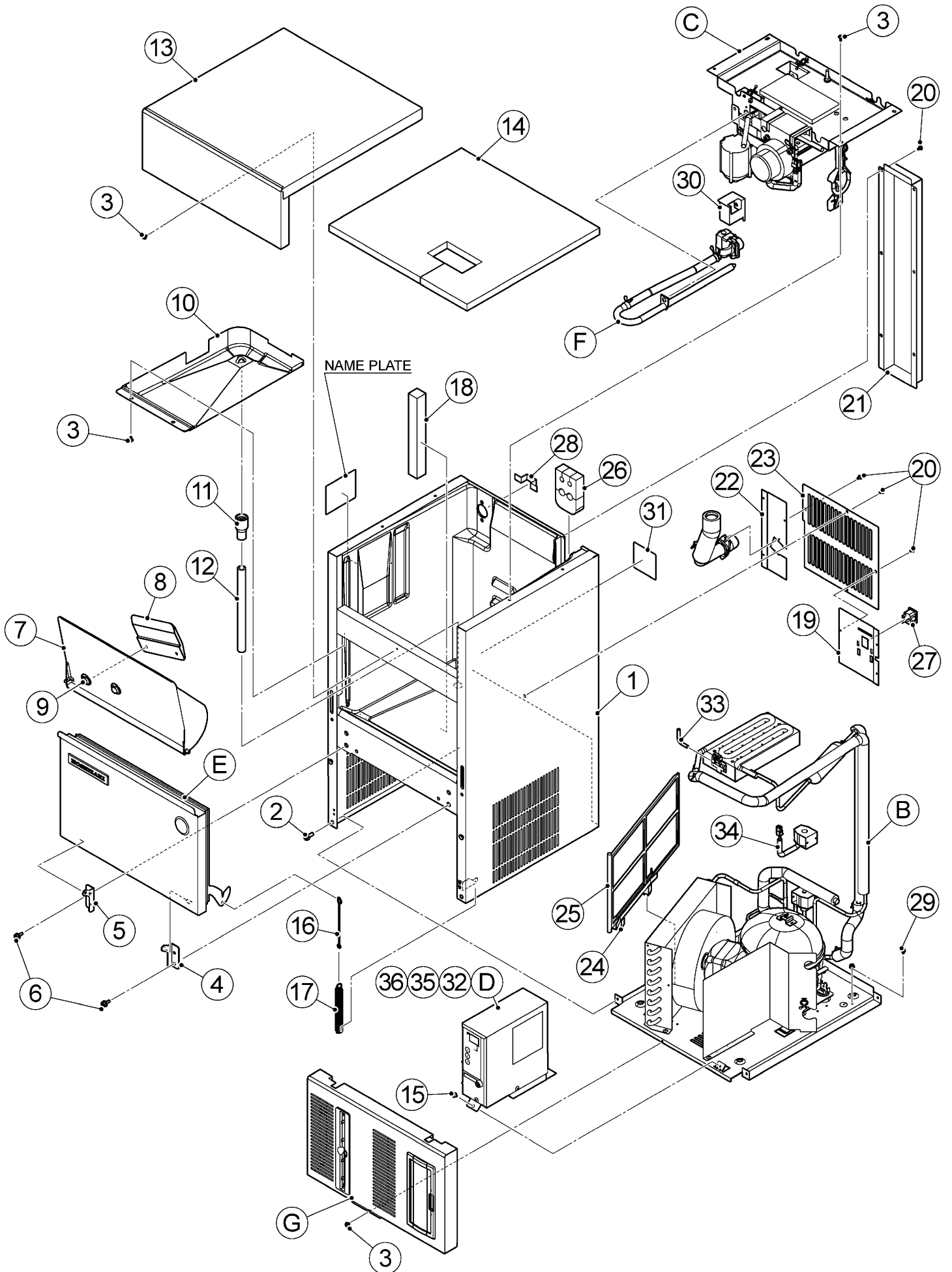

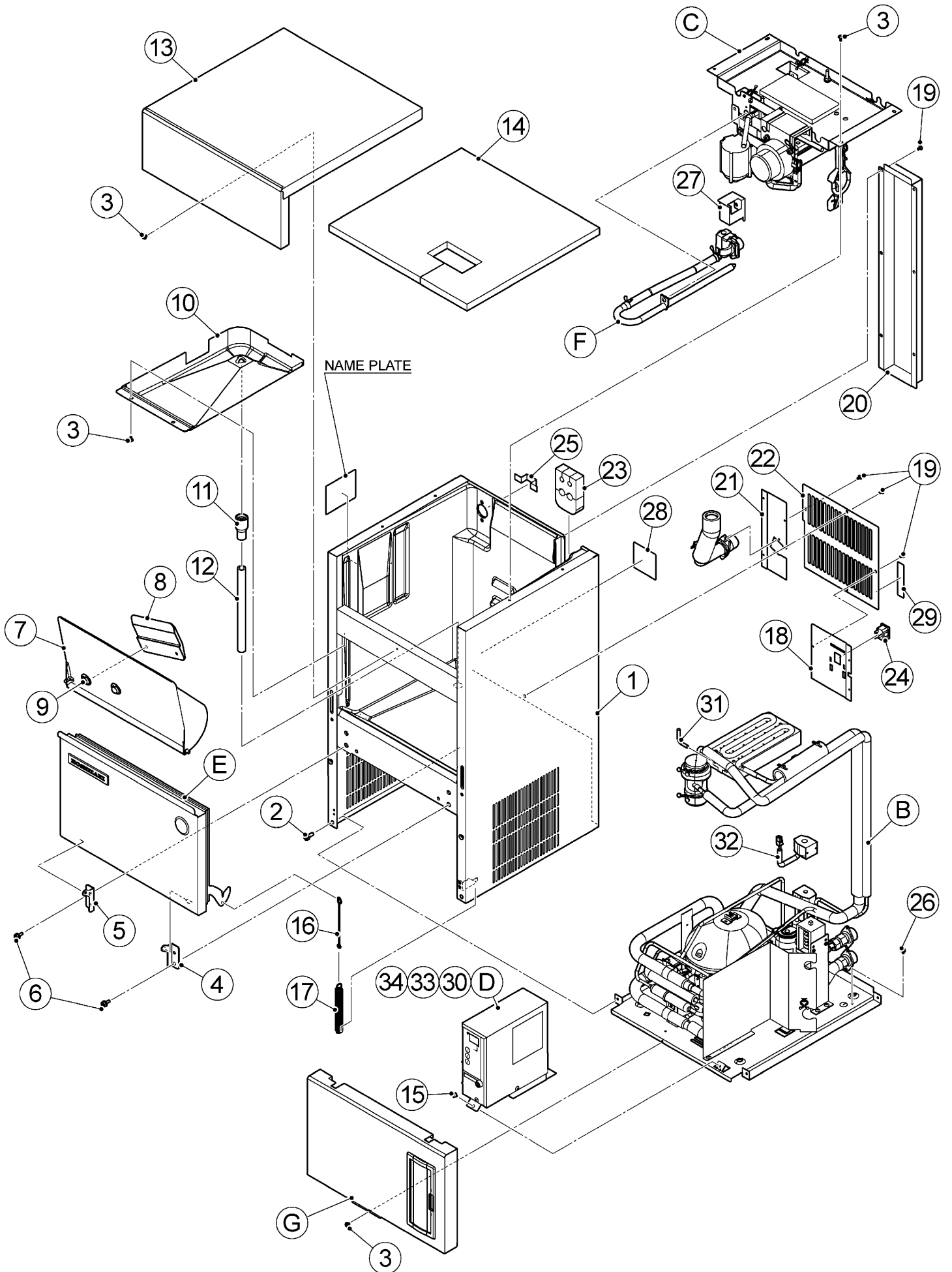

MODEL: **IM-21CPE**
MODEL: **IM-30CPE(-25)**

TITLE: **A. ICE FLAKER ASSY**

INDEX NO.	DESCRIPTION	MATERIAL OR MODEL NUMBER	PART NUMBER	REQ'D NUMBER				
				P-0				
B	REFRIGERATION ASSY		1E0111A01	1				
C	ICE MAKING MECHANISM ASSY		1E0112A01	1				
D	CONTROL BOX ASSY		3E0346A01	1				
E	DOOR ASSY		3E0168A01	1				
F	WATER CIRCUIT ASSY		3E0252A01	1				
G	FRONT PANEL(LOWER)		3E0253G01	1				
P	ACCESSORIES		A04615-01	1				
1	UNIT FRAME		1E0110G01	1				
2	TAPPING SCREW - HEX		442040-01	4				
3	T2 TRUSS HEAD SCREW		FT20408S0	4				
4	HINGE (RIGHT)		3E0327M01	1				
5	HINGE (LEFT)		3E0327M02	1				
6	HEX HEAD BOLT (SPRING WASHER AND FLAT WASHER)		FBK0620S0	4				
7	SLOPE (A)		3E0347G01	1				
		Scoop Holder Parts	3H3628-01	1				
8	HOLDER - SCOOP	Scoop Holder Parts	393026G01	1				
9	THUMB SCREW	Scoop Holder Parts	456279G01	2				
10	DRAIN PAN		2H1442-01	1				
11	DRAIN HOSE		4Z0986R01	1				
12	DRAIN PIPE		4Y7493P02	1				
13	FRONT PANEL (UPPER)		3E0170G01	1				
14	INSULATION - TOP		3Y5954P02	1				
15	S-TITE TRUSS HEAD SCREW		FTS0408M0	4				
16	HOOK		404060-08	1				
17	SPRING		4H0491-01	1				
18	SEAL(B)		4Y7171P01	1				
19	BRACKET - MAINS		3E0174M01	1				
20	T2 TRUSS HEAD SCREW		FT20408F0	14				
21	COVER - PIPE		3E0172M01	1				
22	DRAIN - BRACKET		3E0254M01	1				
23	REAR PANEL		3E0255M01	1				
24	FILTER-RAIL		3Y3497P01	1				

MODEL: IM-30CWPE(-25)

TITLE: A. ICE FLAKER ASSY

INDEX NO.	DESCRIPTION	MATERIAL OR MODEL NUMBER	PART NUMBER	REQ'D NUMBER			
				P-0			
B	REFRIGERATION ASSY		1E0147A01	1			
C	ICE MAKING MECHANISM ASSY		1E0112A01	1			
D	CONTROL BOX ASSY		3E0346A01	1			
E	DOOR ASSY		3E0168A01	1			
F	WATER CIRCUIT ASSY		3E0252A01	1			
G	FRONT PANEL(LOWER)		3E0253G02	1			
P	ACCESSORIES		A04309-01	1			
1	UNIT FRAME		1E0110G01	1			
2	TAPPING SCREW - HEX		442040-01	4			
3	T2 TRUSS HEAD SCREW		FT20408S0	8			
4	HINGE (RIGHT)		3E0327M01	1			
5	HINGE (LEFT)		3E0327M02	1			
6	HEX HEAD BOLT (SPRING WASHER AND FLAT WASHER)		FBK0620S0	4			
7	SLOPE (A)		3E0347G01	1			
		Scoop Holder Parts	3H3628-01	1			
8	HOLDER - SCOOP	Scoop Holder Parts	393026G01	1			
9	THUMB SCREW	Scoop Holder Parts	456279G01	2			
10	DRAIN PAN		2H1442-01	1			
11	DRAIN HOSE		4Z0986R01	1			
12	DRAIN PIPE		4Y7493P02	1			
13	FRONT PANEL (UPPER)		3E0170G01	1			
14	INSULATION - TOP		3Y5954P02	1			
15	S-TITE TRUSS HEAD SCREW		FTS0408M0	4			
16	HOOK		404060-08	1			
17	SPRING		4H0491-01	1			
18	BRACKET - MAINS		3E0174M01	1			
19	T2 TRUSS HEAD SCREW		FT20408F0	14			
20	COVER - PIPE		3E0172M01	1			
21	DRAIN - BRACKET		3E0254M01	1			
22	REAR PANEL		3E0255M01	1			
23	INSULATION-BIN		4Y7416P01	1			
24	CONNECTOR		P00245-02	1			

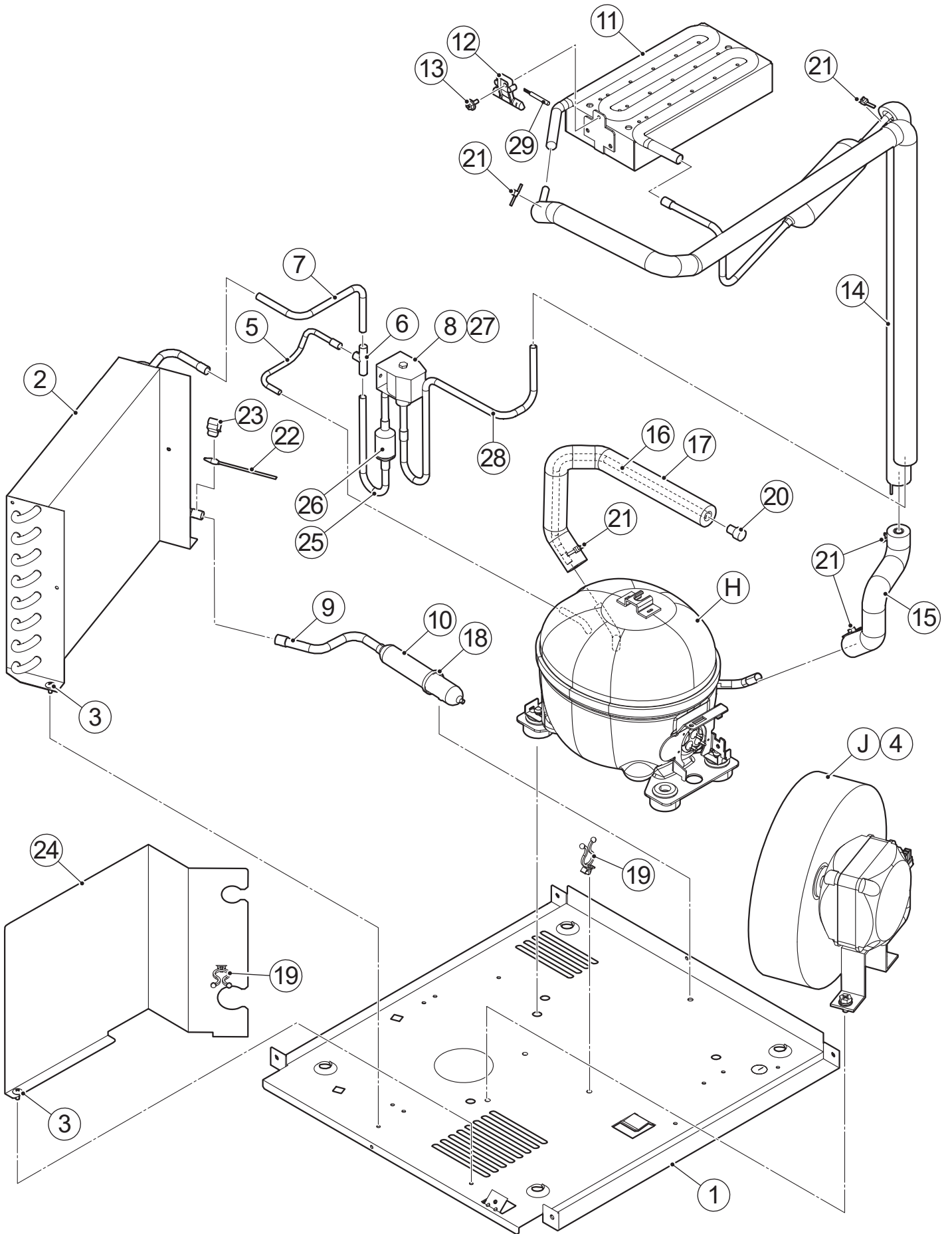

MODEL: IM-21CPE

TITLE: B. REFRIGERATION ASSY

MODEL: IM-30CPE(-25)

INDEX NO.	DESCRIPTION	MATERIAL OR MODEL NUMBER	PART NUMBER	REQ'D NUMBER				
				P-0				
H	COMPRESSOR ASSY		381641A01	1				
J	FAN MOTOR ASSY		3E0305A01	1				
1	BASE		1E0114M01	1				
2	CONDENSER		P03554-01	1				
3	T2 TRUSS HEAD SCREW		FT20408F0	4				
4	HEX HEAD BOLT (SPRING WASHER AND FLAT WASHER)		FBK0612F0	2				
5	COPPER TUBE(A) - HIGH SIDE		3E0257M01	1				
6	TEE - 6.4		417394-01	1				
7	COPPER TUBE - CONDENSER		4E0168M01	1				
8	HOT GAS VALVE METAL COMPONENT		P02539-0A	1				
9	COPPER TUBE-DRIER		4Y7173M01	1				
10	DRIER		P03584-01	1				
11	EVAPORATOR		2X6724G02	1				
		25mm	2X6723G01	1				
12	HOLDER - THERMISTOR		315479-01	1				
13	Flange Bolt (C-TITE)		FTR0408M0	1				
14	HEAT EXCHANGER ASSY		3E0259G01	1				
15	COPPER TUBE (L)		3E0260G01	1				
16	PROCESS TUBE		4E0169M01	1				
17	Insulation Tube		H71022300	1				
18	CABLE TIE		P05042-01	1				
19	CLAMP		P05216-01	2				
20	LOCKRING STOPPER		P01677-01	1				
21	TIE		7920-0002	5				
22	THERMISTOR-FILTER		4R2692-07	1				
23	CLIP-THERMISTOR		4R2938-01	1				
24	BARRIER		3E0261M01	1				
25	COPPER TUBE (A2) - HOT GAS		4E0171M01	1				
26	STRAINER		P00008-01	1				
27	HOT GAS VALVE ELECTRICAL COIL		4E0251G01	1				
28	PIPE (B) - HOT		3E0186M01	1				
29	THERMISTOR-CUBE CONTROL		P00350-03	1				

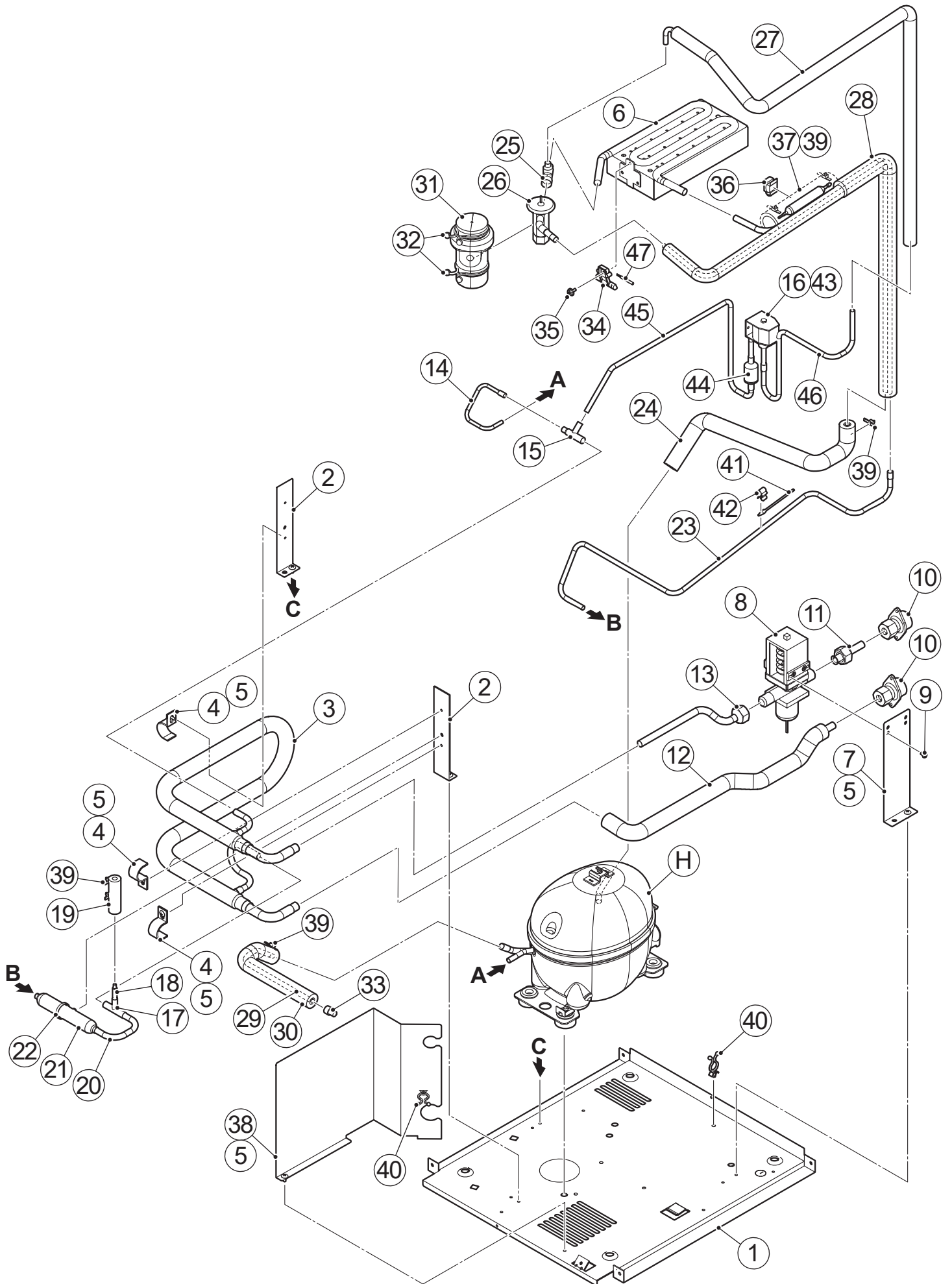

MODEL: IM-30CWPE(-25)

TITLE: B. REFRIGERATION ASSY

INDEX NO.	DESCRIPTION	MATERIAL OR MODEL NUMBER	PART NUMBER	REQ'D NUMBER				
				P-0				
H	COMPRESSOR ASSY		381641A01	1				
1	BASE		1E0114M01	1				
2	BRACKET - CONDENSER		4H5731-01	2				
3	CONDENSER-WATER COOLED		2X0722G01	1				
4	CLAMP(B)-CONDENSER		4H0622-01	3				
5	T2 TRUSS HEAD SCREW		FT20408F0	11				
6	EVAPORATOR	28mm	2X6724G02	1				
		25mm	2X6723G01	1				
7	BRACKET - WATER REGULATOR		4E0134M01	1				
8	WATER REGULATOR		P05382-01	1				
9	PAN HEAD SCREW		FSP0406S0	2				
10	FITTING(P)		3Y0747A01	2				
11	PIPE(C) - WATER		4Y7391A01	1				
12	PIPE(A)-WATER SUPPLY		4E0190G01	1				
13	PIPE(B)-WATER SUPPLY		4E0191G01	1				
14	PIPE (A) - HIGH SIDE		4E0192M01	1				
15	TEE		420041-03	1				
16	HOT GAS VALVE METAL COMPONENT		P02539-0A	1				
17	TEE		420041-02	1				
18	SLEEVE		441322-01	1				
19	Insulation Tube		H71020A55	1				
20	COPPER TUBE		4Y7432M01	1				
21	DRIER		P04629-01	1				
22	CABLE TIE		P05042-01	1				
23	PIPE (C) - HIGH SIDE		4E0193M01	1				
24	COPPER TUBE(A) - LOW SIDE		3E0312G01	1				
25	TEE		420335-01	1				
26	EXPANSION VALVE		P05535-01	1				
27	PIPE (A)-HOT GAS		3E0313G01	1				
28	HEAT EXCHANGER		2E0238G01	1				
29	PROCESS TUBE A		4E0194M01	1				
30	Insulation Tube		H71022205	1				

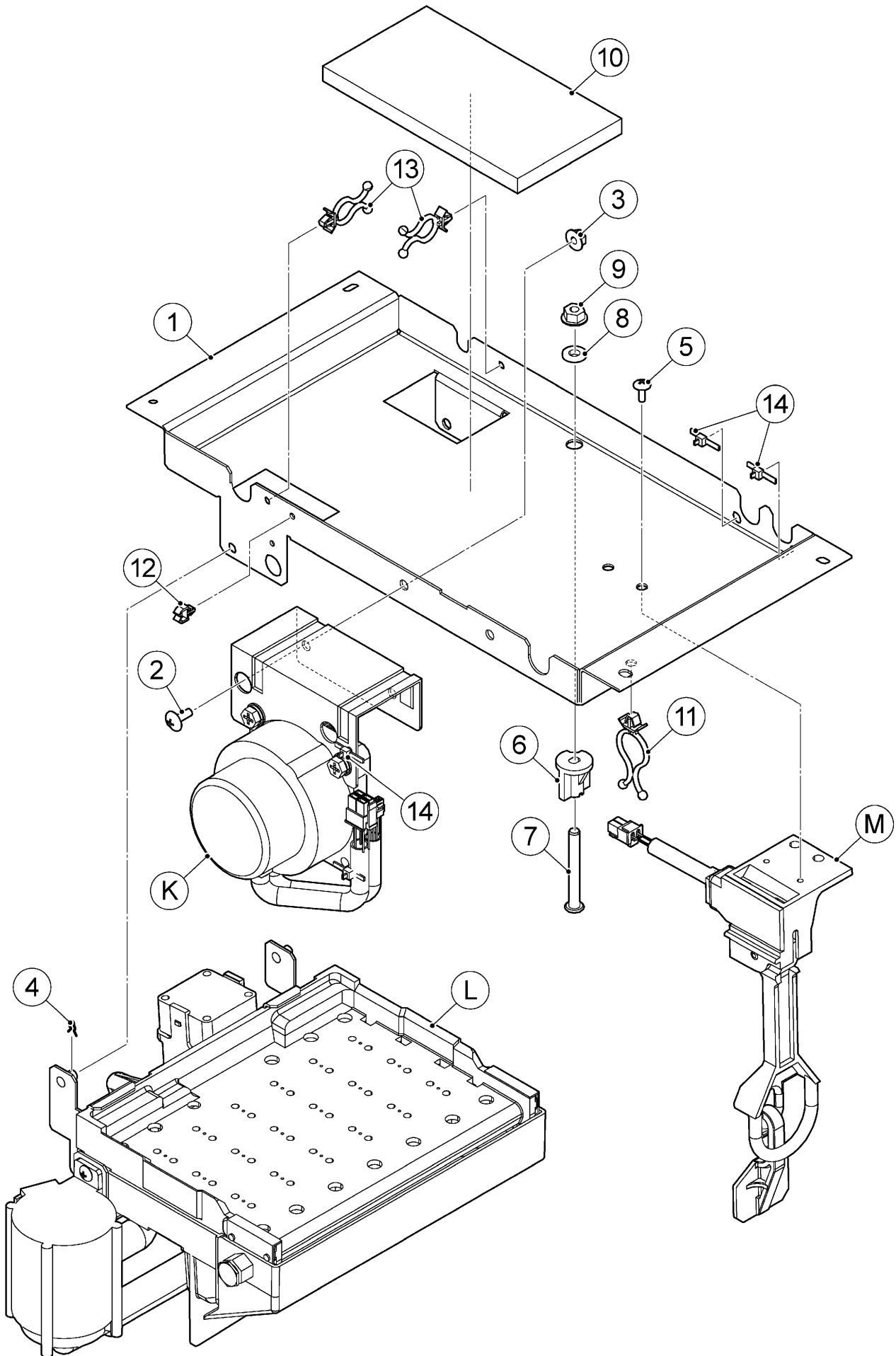

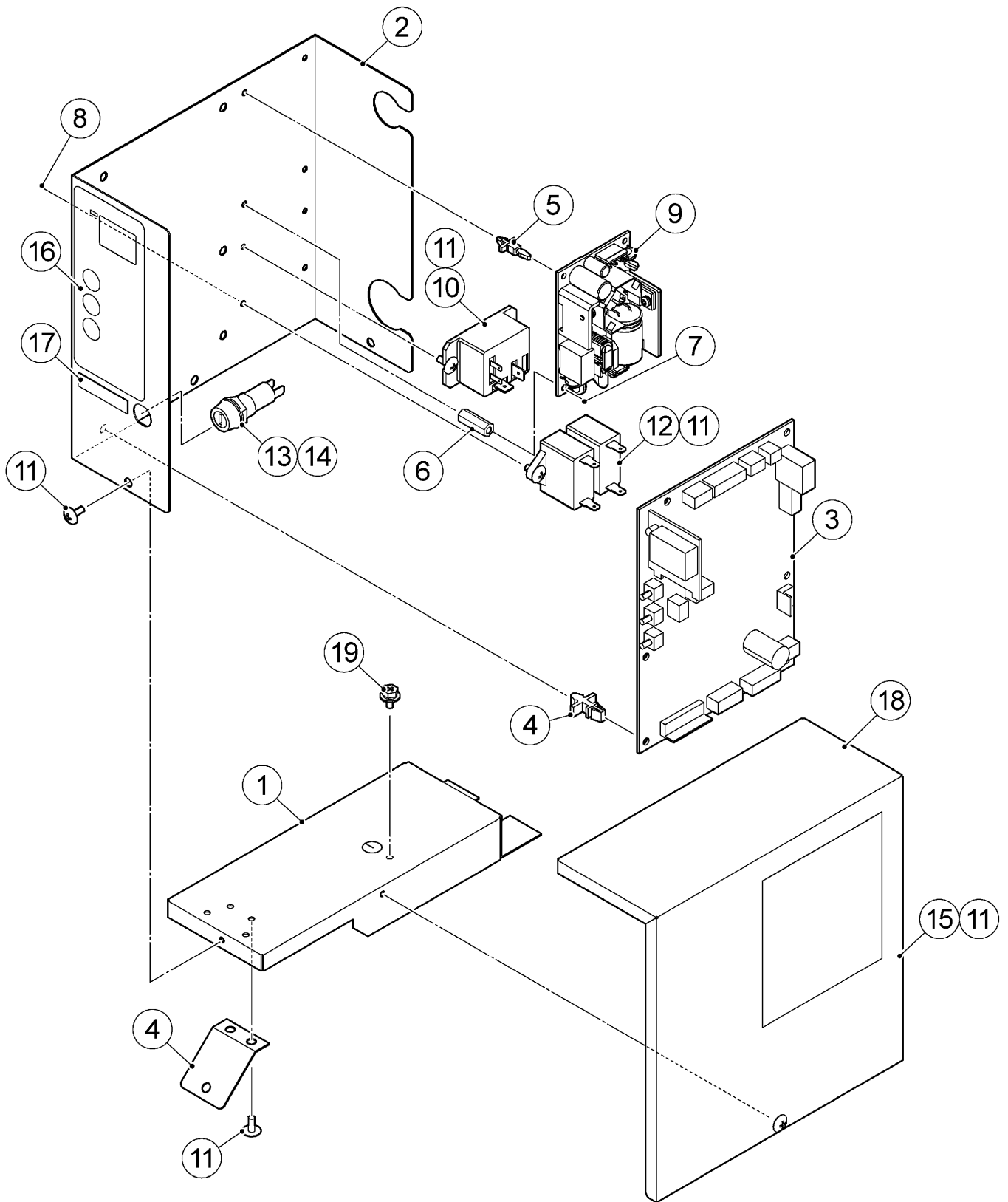

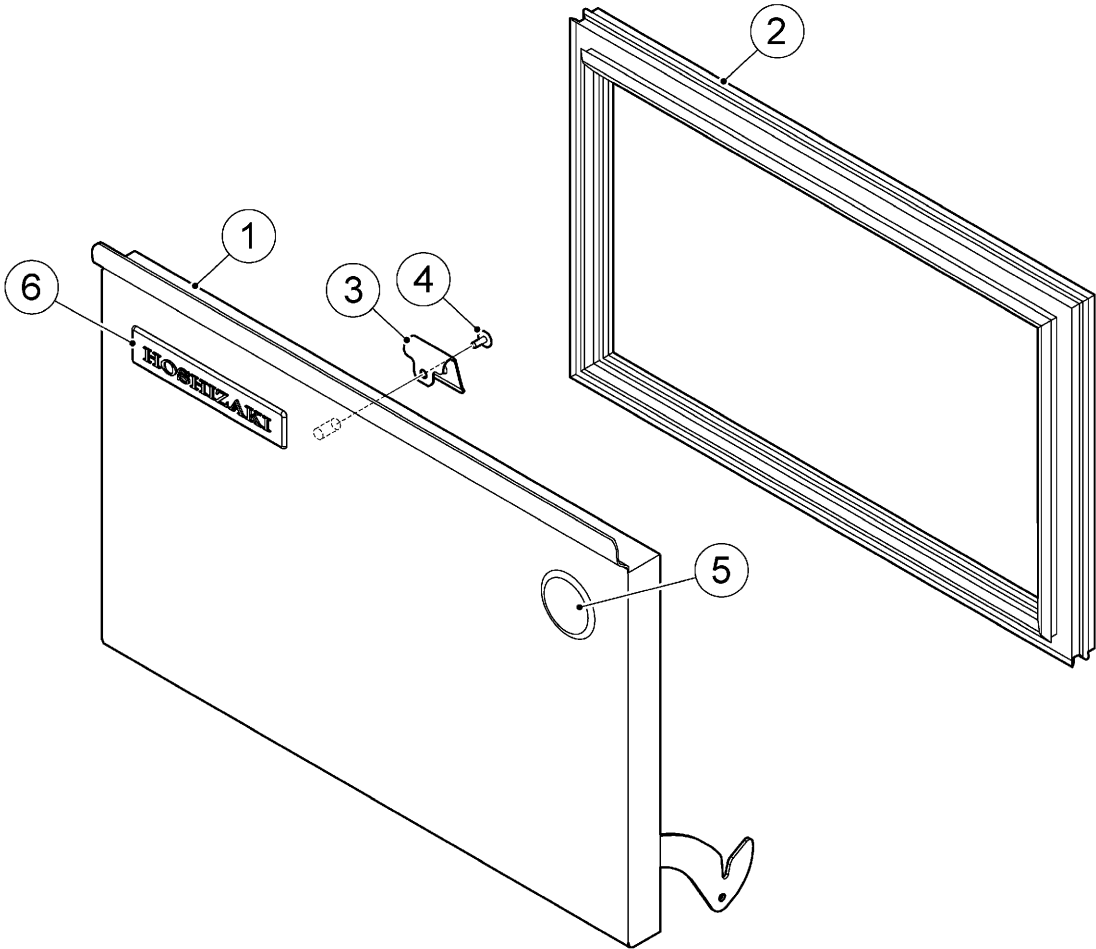

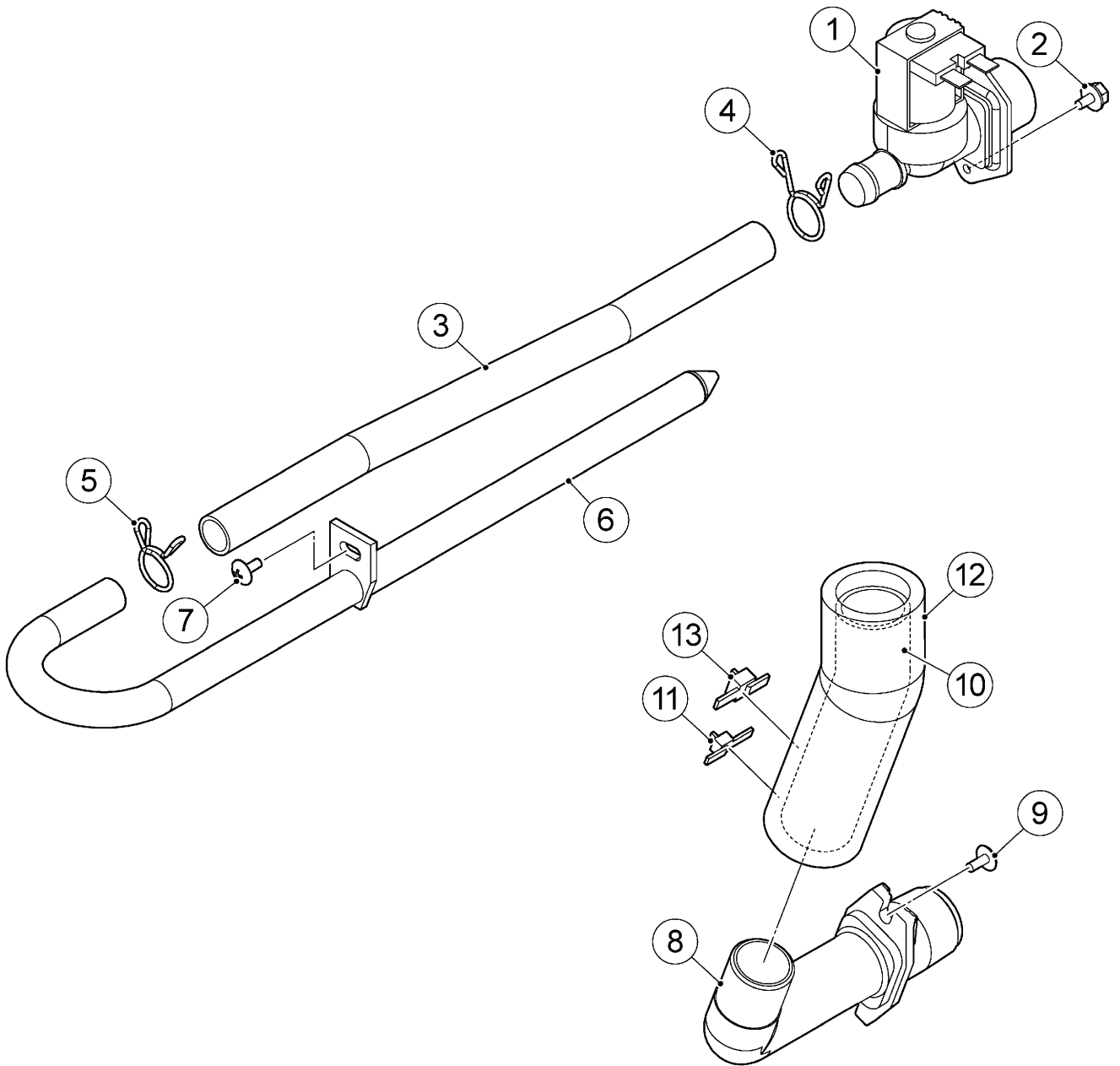

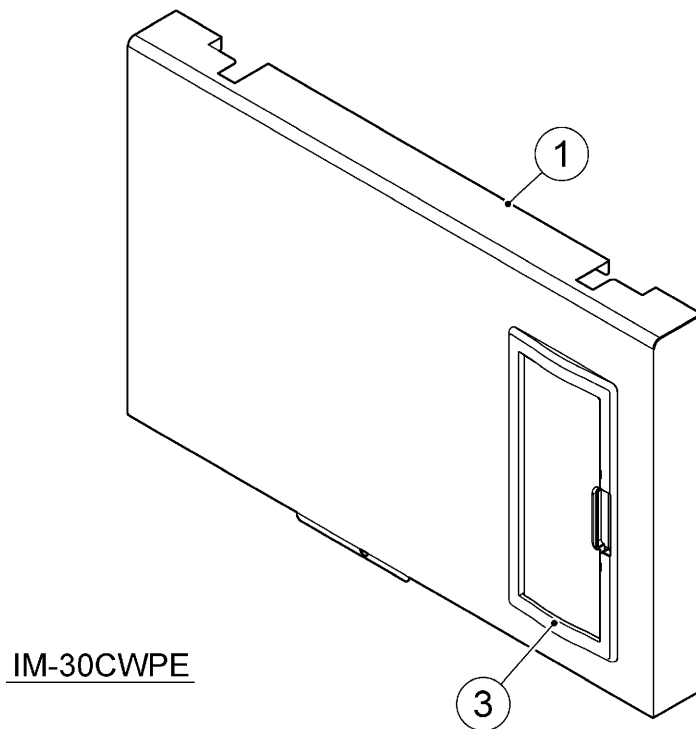
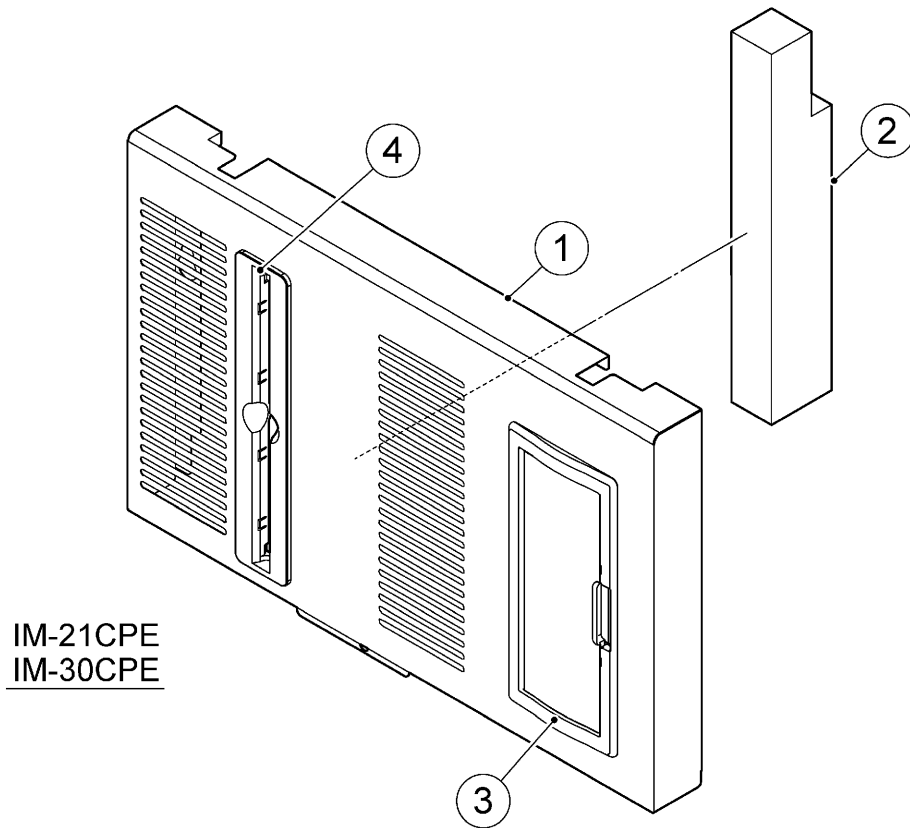

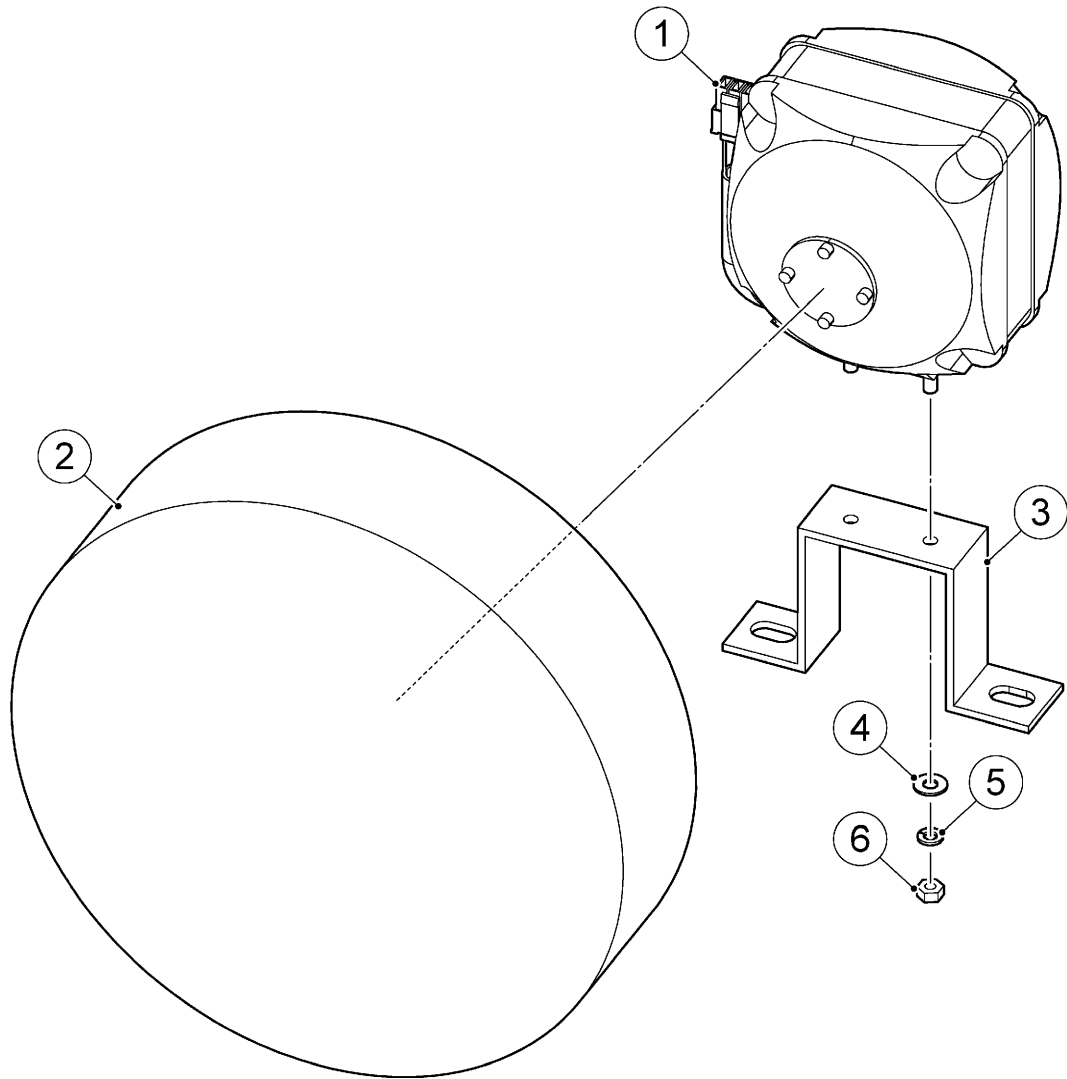

HE

MODEL: IM-21CPE		TITLE: J. FAN MOTOR ASSY					
MODEL: IM-30C(W)PE(-25)							
INDEX NO.	DESCRIPTION	MATERIAL OR MODEL NUMBER	PART NUMBER	REQ'D NUMBER			
				P-0			
1	FM ASSY (A)	REGAL	4E0246G01	1			
2	FAN		P06537-01	1			
3	BRACKET - FM		P05871-01	1			
4	FLAT WASHER		FWPL04S0	2			
5	SPRING WASHER		FWSP04S0	2			
6	NUT		FNH104S0	2			

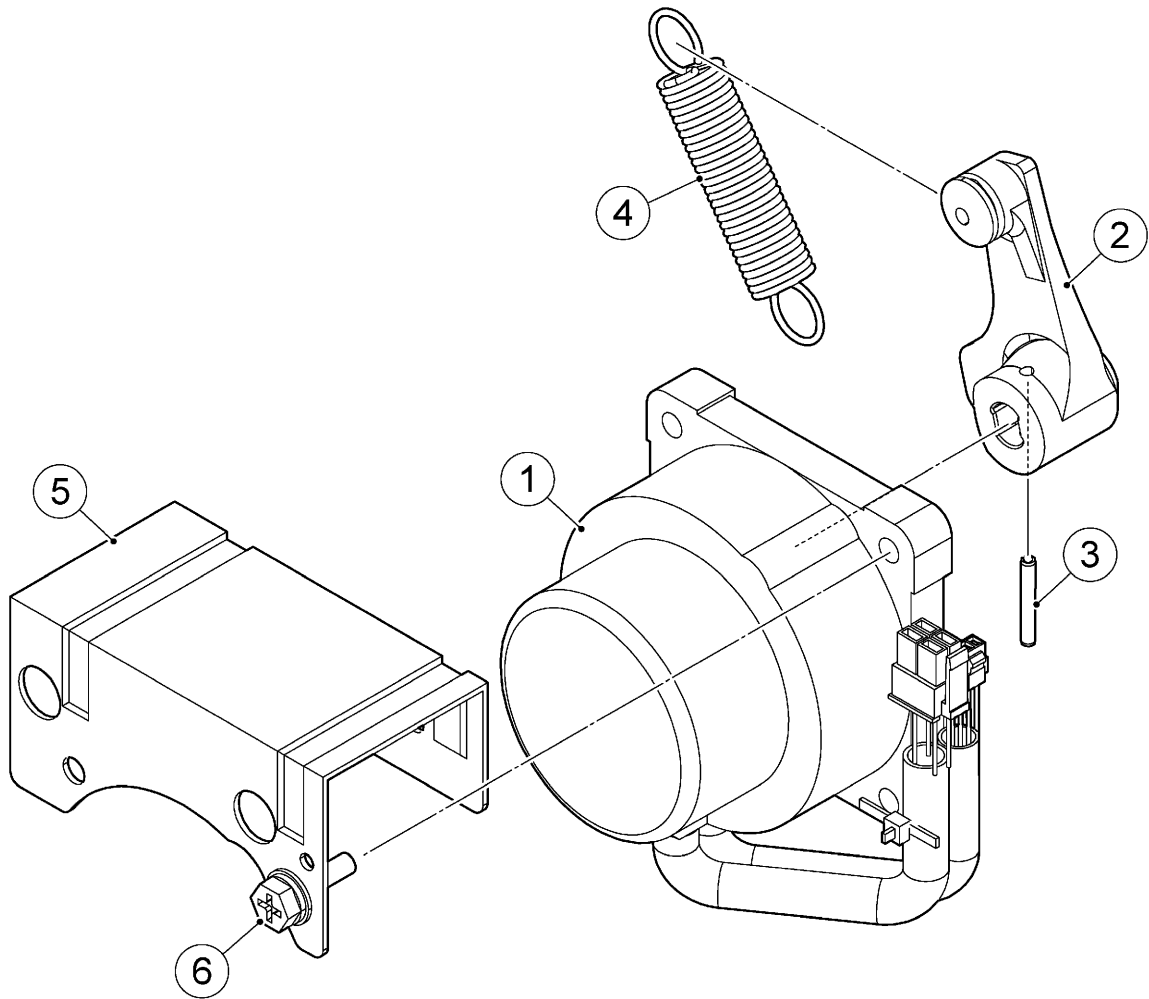

IM-21CPE
IM-30CPE
IM-30CWPE

L. WATER PAN ASSY

(P-0) and later

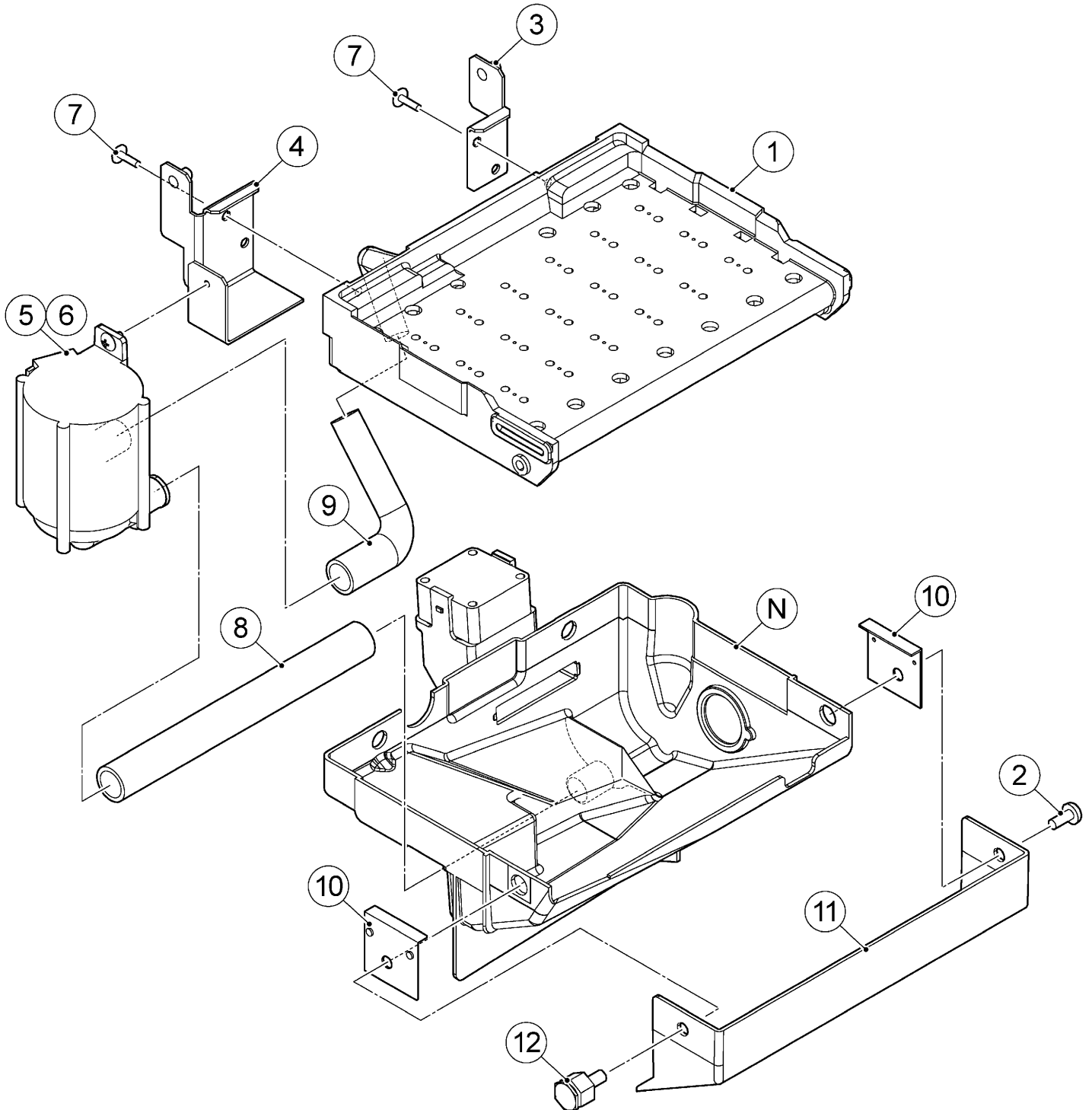

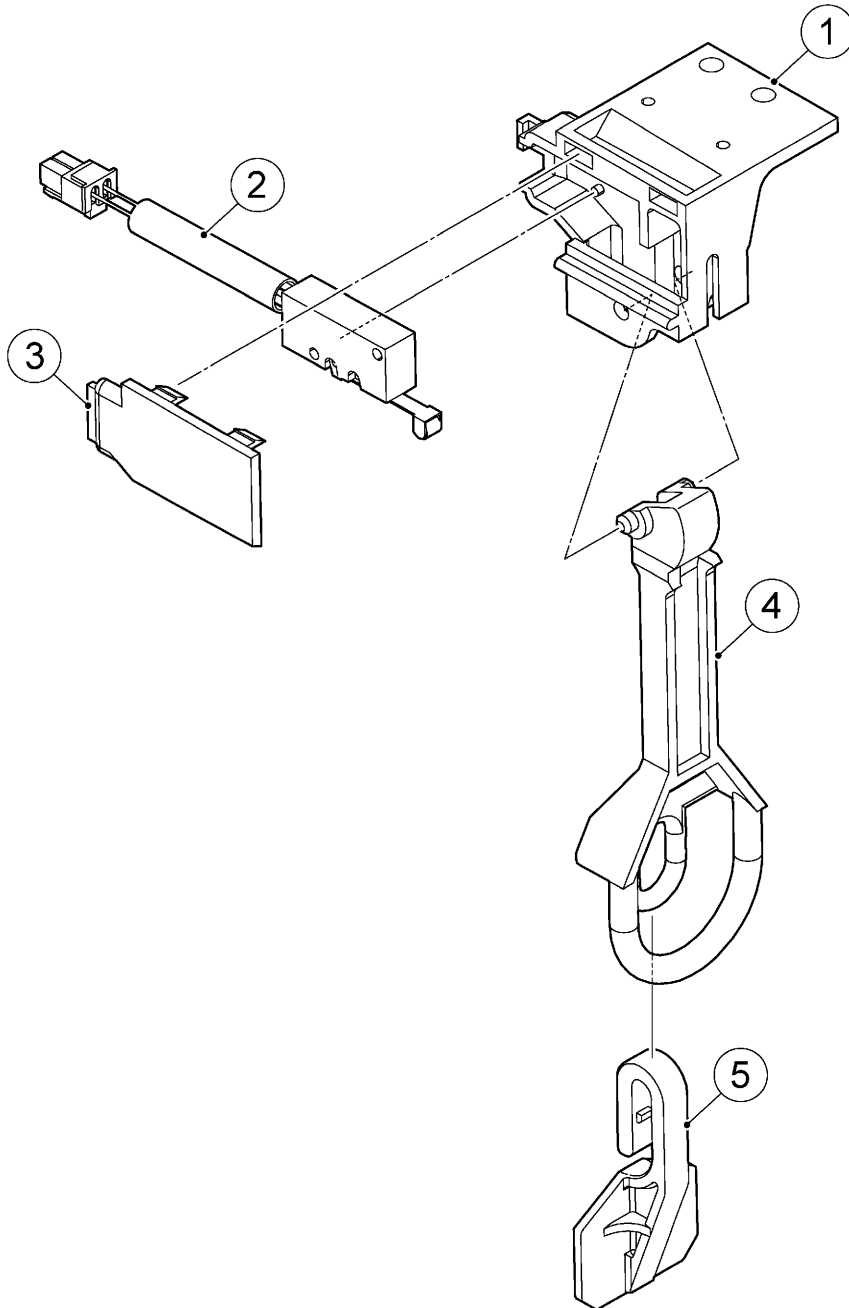

HE

MODEL: IM-21CPE		TITLE: M. BIN CONTROL SWITCH ASSY					
MODEL: IM-30C(W)PE(-25)							
INDEX NO.	DESCRIPTION	MATERIAL OR MODEL NUMBER	PART NUMBER	REQ'D NUMBER			
				P-0			
1	SWITCH BOX		2H2043-01	1			
2	BS ASSY (A)		4E0250G02	1			
3	SWITCH BOX COVER		4H8785-01	1			
4	SWITCH ACTUATOR		3H1369-01	1			
5	DETECTOR		3X1279-01	1			

IM-21CPE
IM-30CPE
IM-30CWPE

N. WATER PAN AD3

(D-1) and later

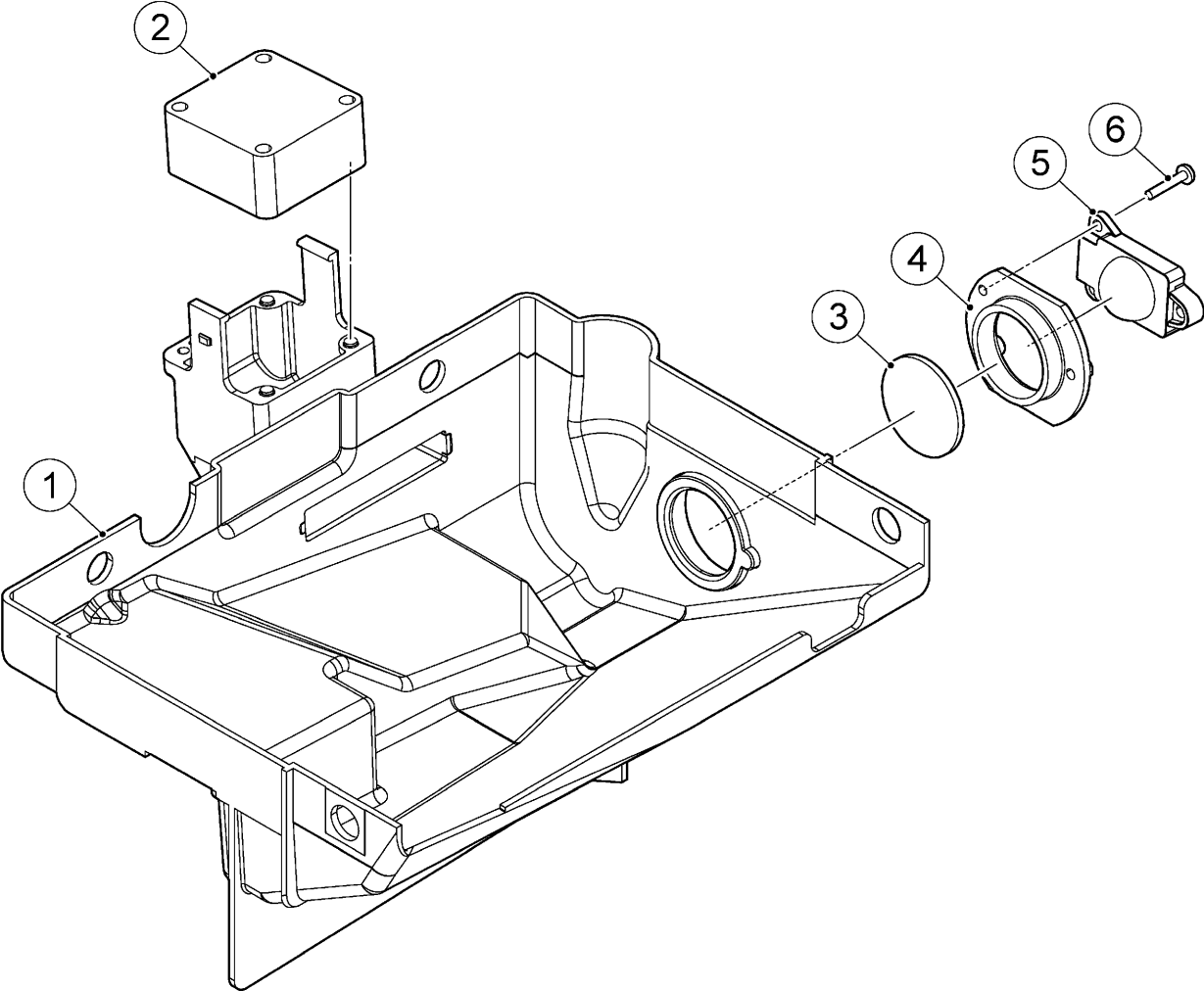

HE

MODEL: IM-21CPE		TITLE: N. WATER PAN AD3					
MODEL: IM-30C(W)PE(-25)							
INDEX NO.	DESCRIPTION	MATERIAL OR MODEL NUMBER	PART NUMBER	REQ'D NUMBER			
				P-0			
1	WATER PAN AD3		4E0216G01	1			
2	FAN MOTOR		P06703-01	1			
3	WINDOW - GASKET		P06651-01	1			
4	HOLDER - LED		3E0331P01	1			
5	UVC-LED		P06697-01	1			
6	PAN HEAD MACHINE SCREW		FT50314S0	3			

